

HD STREET GLIDE FLHX '24-

M O U N T I N G I N S T R U C T I O N S

REF 23032

HIGH ROAD SPORT SCREEN



1 Person



20 min









EASY

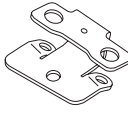
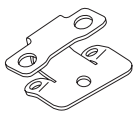

TORX
T25
T27



ID	PIEZA/PART	DESCRIPCIÓN	DESCRIPTION	QTY	REF
1		Cúpula sport	Sport Screen	1	23032H/W/F/N/R/ T/G/JM3
2		Soporte derecho (•)	Right support (•)	1	SOPOR2P1-R23032
3		Soporte Izquierdo	Left Support	1	SOPOR2P1-L23032
4		Tope de goma Ø12x4mm	Ø12x4mm Bumper foot	2	TOPEGOMA--21950
5		Tope de goma Ø11x Ø5,5x 7mm	Ø11x Ø5,5x 7mm Bumper foot	2	TOPEGOMA--22384
6		Silentblock con casquillo incorporado Ø17xØ5,25x7,5mm	Ø17xØ5,25x7,5mm Silentblock witch integrated bush with flange	4	SILENT+CASQUI-1
7		Tornillo Torx M5x16 DIN912	M5x16 DIN912 Torx screw	4	TORNIII4579-980
8		Silentblock M5	M5 Silentblock	4	SILENBTM5-046/1

HD STREET GLIDE FLHX '24-

INSTRUCCIONES DE MONTAJE - MOUNTING INSTRUCTIONS - MONTAGEANLEITUNG

1

DISASSEMBLY
DESMONTAJE

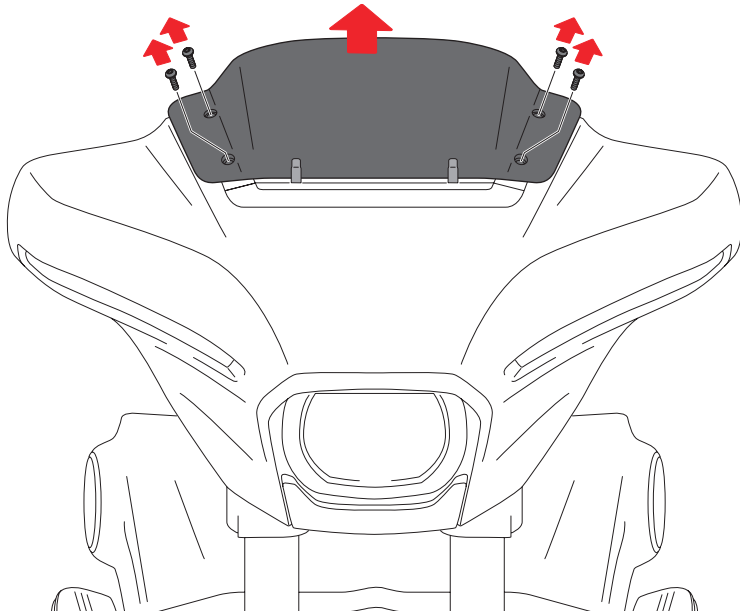

2

DISASSEMBLY
DESMONTAJE

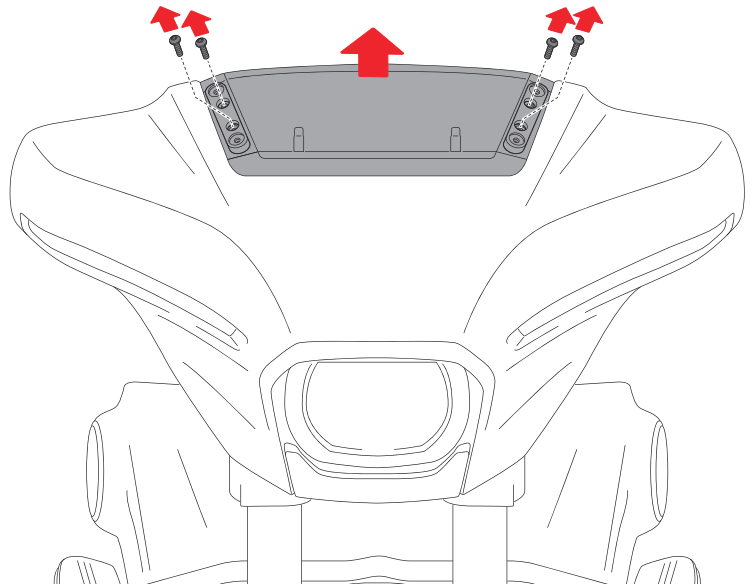

3

DISASSEMBLY
DESMONTAJE

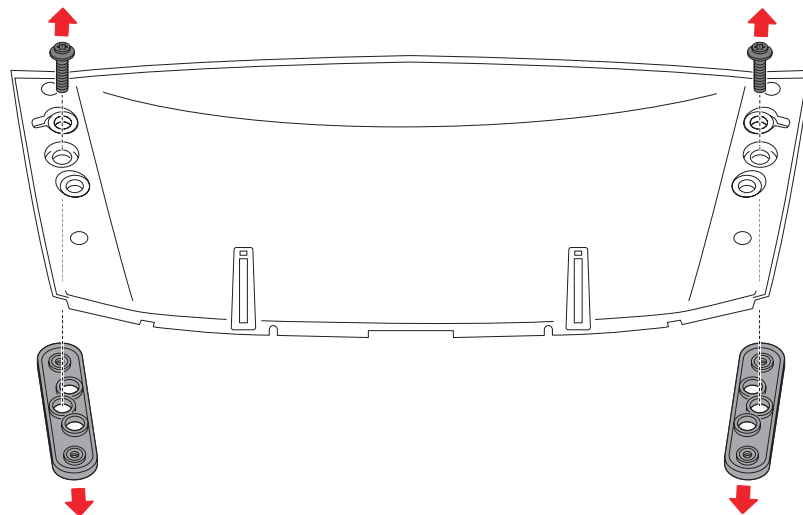
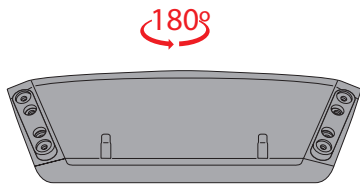

REMOVE ORIGINAL SUPPORTS

HD STREET GLIDE FLHX '24-

INSTRUCCIONES DE MONTAJE - MOUNTING INSTRUCTIONS - MONTAGEANLEITUNG

4

ASSEMBLY
MONTAJE

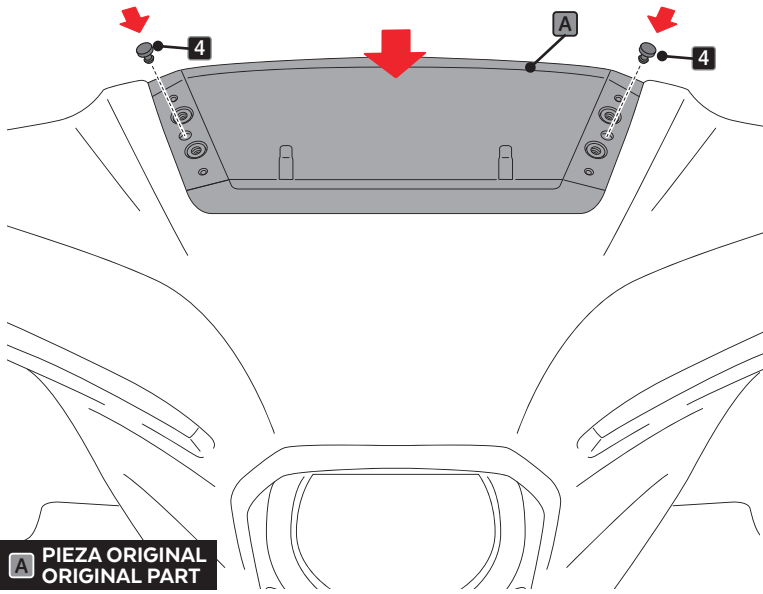

A PIEZA ORIGINAL
ORIGINAL PART

5

ASSEMBLY
MONTAJE

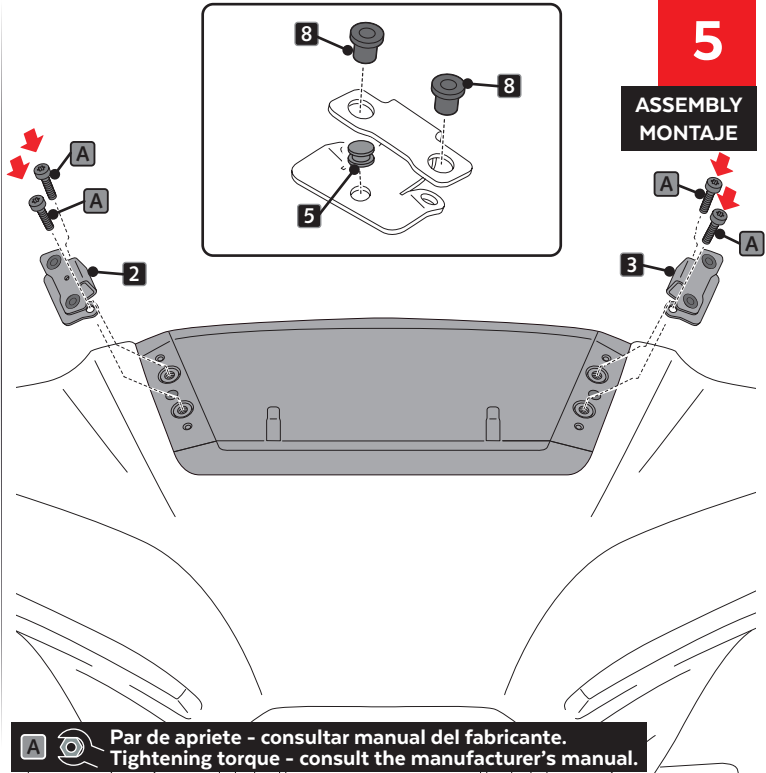

A Par de apriete - consultar manual del fabricante.
Tightening torque - consult the manufacturer's manual.

6

ASSEMBLY
MONTAJE

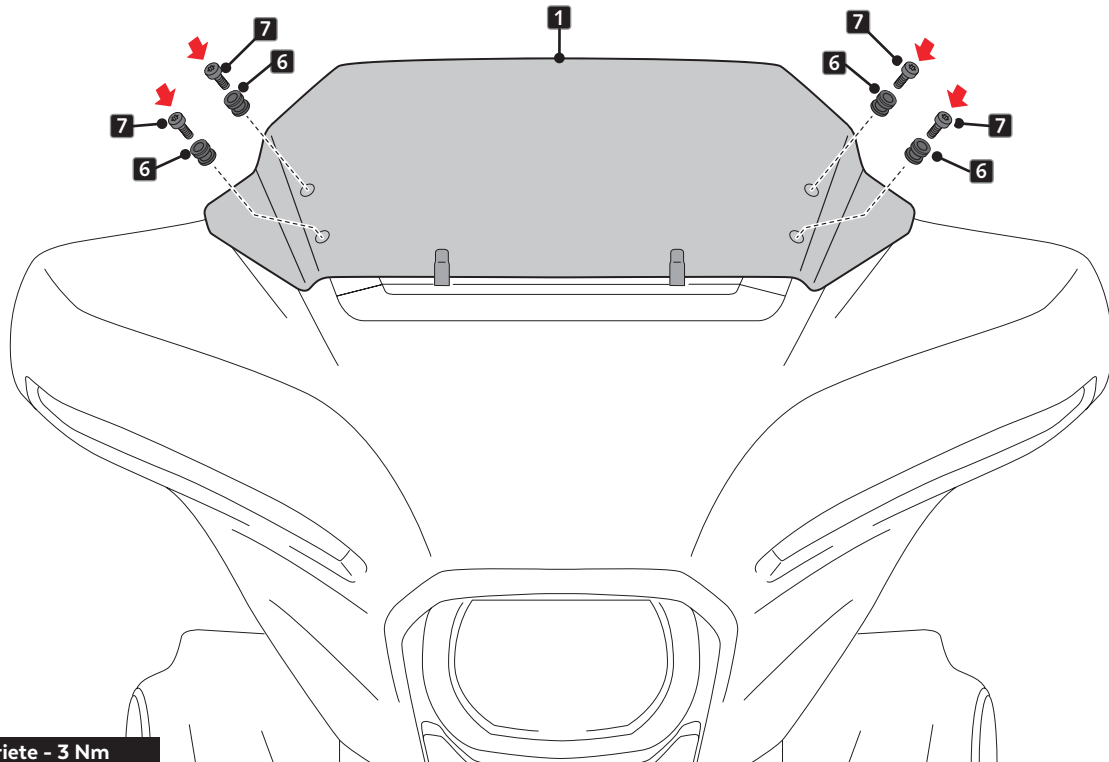

7 Par de apriete - 3 Nm
Tightening torque - 3Nm